



Kawasaki KX 250 F,  
Suzuki RM 250 Z(2004, 2005)

Slip-On Exhaust System

# Akrapovic Slip-On Exhaust System

for the Kawasaki KX 250F, Suzuki RM 250 Z (2004, 2005)

First it should be mentioned that the engines for the Kawasaki KX 250 F and Suzuki RM 250 Z the are identical, so that the performance data and configuration for the two systems are the same. The Akrapovic SLIP-ON exhaust system is a first-level tuning component intended mainly for amateur riders. No special mechanical skills are required for installation, and its low price in comparison with the stock component also makes it suitable for amateur riding, where damage to exhaust systems is a more frequent occurrence. The Akrapovic SLIP-ON is available with two noise dampers, an MX and an Enduro, so that it conforms to FIM regulations with regard to exhaust system noise levels for both types of competition. And of course in addition to the increase in power and torque, the Akrapovic SLIP-ON system will add an aesthetic touch and the renown of a famous brand name to the character and lines of your Kawasaki KX 250 F.

For 2005, the Kawasaki delivers more power than the 2004 model.

## PERFORMANCE

### Measurements of the Akrapovic SLIP-ON system on the Kawasaki KX 250 F (98 dB noise damper):

Power: despite the relatively free-flowing stock exhaust system and engine of the Kawasaki (Suzuki), the Akrapovic SLIP-ON system still manages to build on the stock power curve. The increase is felt above 8000 rpm and runs into the overrev range. A slightly lower result than the stock curve is seen at low revs, which we sacrificed for higher power at high revs, since the 250 cc likes to rev and use the power at the top of the range. Torque: the torque curve follows the characteristics of the power curve – lower at the bottom of the range, and from 7800 rpm on a sizeable increase which runs into the overrev range.

## CONFIGURATION

The link pipe for the Akrapovic SLIP-ON system is made of high-quality stainless steel, and is mainly cylindrical, except near the connection to the muffler. Here we used the concept of flared of the tube, which gave us better results than a conical shape. The link pipe is welded to the muffler. At the other end, the link pipe is attached to the stock header assembly with a sleeve joint secured with a metal clamp. The muffler is attached to the frame using an Akrapovic Offroad carbon-fiber clamp.

## OPTIONS

Riders who enjoy both MX and Enduro can also order a 94 dB enduro noise damper for the Akrapovic SLIP-ON exhaust system which conforms to the regulations for FIM Enduro exhaust system noise levels.

	PERFORMANCE		
	stock	AKRAPOVIC	max. increased power
max. rear wheel power HP / rpm (measured on SuperFlow Cycle Dyn)	32 / 11000 (2004) 32.2 / 10800 (2005)	32.5 / 11000 (2004) 33.1 / 10500 (2005)	0.6 / 11500 (2004) 1 / 10600 (2005)

	CONFIGURATION		
	header tubes	collector	link pipe
material	-	-	STAINLESS STEEL
tube shape	-	-	FLARED

interference crossover tubes	-	lambda sensor	-
header tube inner sleeves	-	header tube flanges	-
header tubes - collector connection	-	collector / header tube - link pipe connection	SLEEVE JOINT + METAL CLAMP
link pipe - muffler connection	WELDED	muffler inlet cap /outlet cap	STAINLESS STEEL / TITANIUM
muffler metal interior	STAINLESS STEEL	muffler outer sleeve	TITANIUM
muffler clamp	CARBON-FIBER OFF ROAD	muffler bracket	-
noise damper	FIM MX 98 dB	heat shield	-

OPTIONS			
link pipe	noise damper	muffler bracket	heat shield
-	FIM ENDURO 94 dB	-	-

	ADDITIONAL DATA				
	stock	AKRAPOVIC		difference	
weight comparison (kg)	2.24	S.S. link pipe	TITANIUM link pipe	stock - S.S.	stock - titanium
		2.20	-	0.04	-
noise measurements (dB / rpm)	stock		AKRAPOVIC		
	98 / 5500		98 / 5500		
possibility of periodic service without removing A.E.S.	oil		oil filter		
	YES		YES		
legal for street use	NO				

Technical specifications of Akrapovic exhaust systems and related products subject to change without notice.

# Akrapovic Slip-On Exhaust System

for the Kawasaki KX 250F, Suzuki RM 250 Z (2004, 2005)



98dB FIM MX NOISE DAMPER (INCLUDED)    94dB FIM ENDURO NOISE DAMPER (OPTIONAL)



CARBON-FIBER  
MUFFLER CLAMP

# Akrapovic Slip-On Exhaust System

for the Kawasaki KX 250F, Suzuki RM 250 Z (2004, 2005)



Akrapovic Exhaust System Technology copyright 2005, all rights reserved

Off-Road  
Program

# Akrapovic Slip-On Exhaust System

for the Kawasaki KX 250F, Suzuki RM 250 Z (2004, 2005)



Akrapovic Exhaust System Technology copyright 2005, all rights reserved

Off-Road  
Program

Product code: 102429 (S-K2S01-MT)



# Akrapovic Slip-On Exhaust System

for the Kawasaki KX 250F, Suzuki RM 250 Z (2004, 2005)

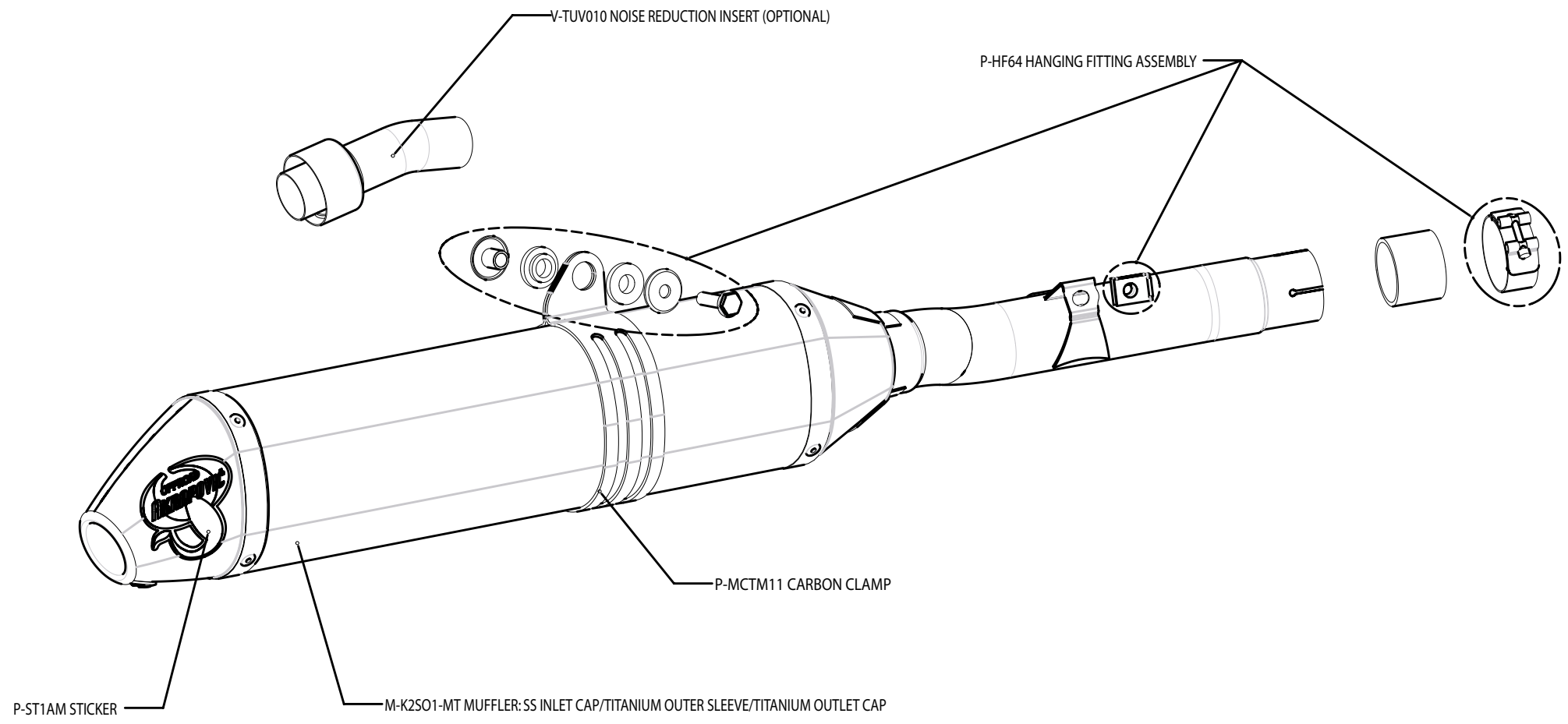

Off-Road Program

Akrapovic Exhaust System Technology copyright 2005, all rights reserved



# Akrapovic Slip-On Exhaust System

for the Kawasaki KX 250F, Suzuki RM 250 Z (2004, 2005)

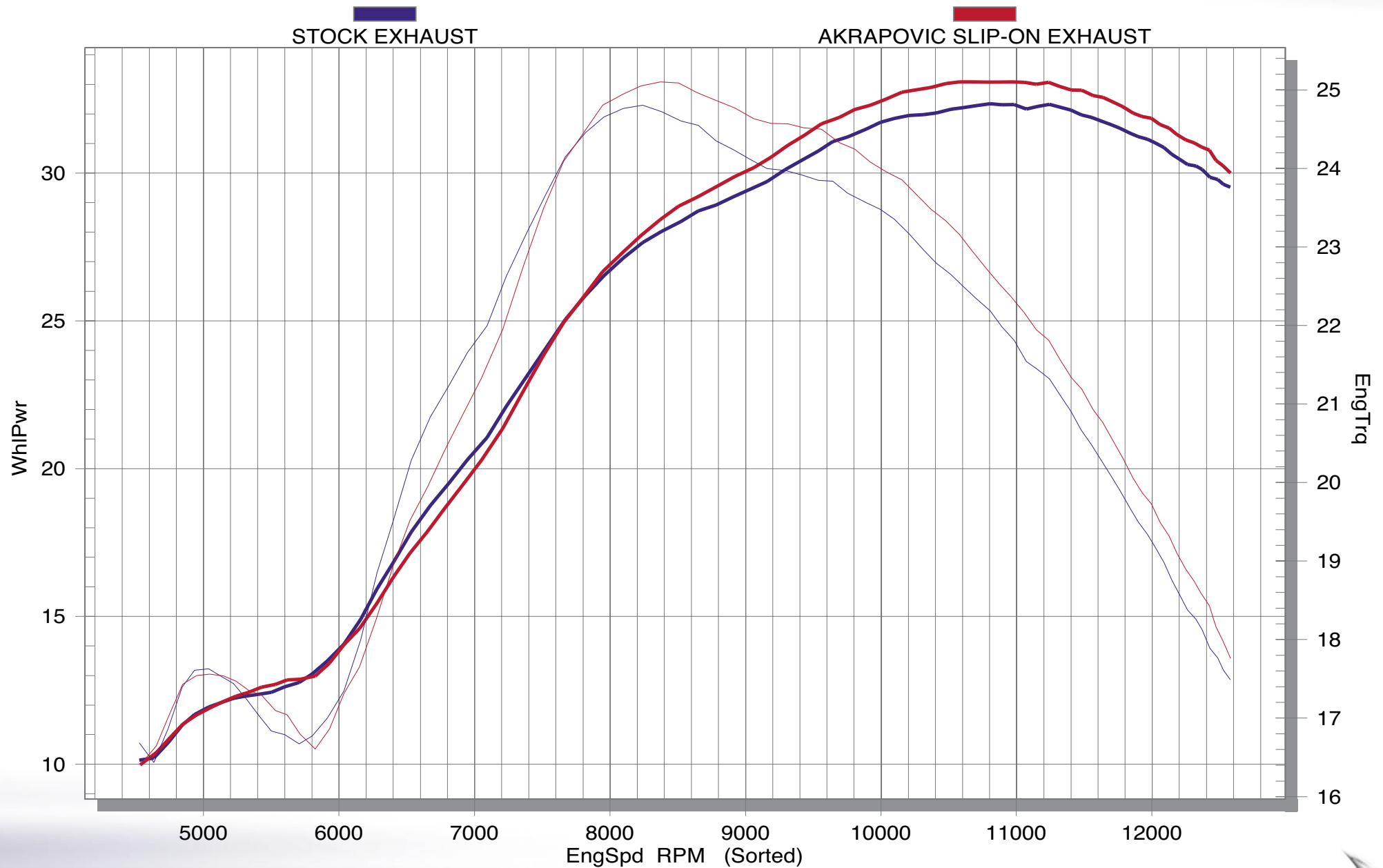

Akrapovic Exhaust System Technology copyright 2005, all rights reserved

Off-Road Program

